

RSG-862 EFI

6.2 Liter
V-8

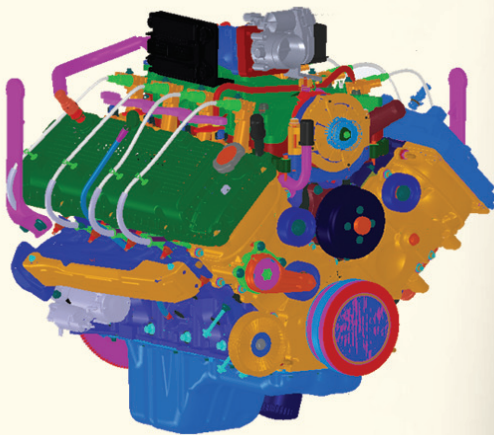

Options

Engine Cooling Fans

- 18" (457mm) diameter suction
- 18" (457mm) diameter pusher

Flywheels

- 11.5" SAE
- flat face flywheel

Flywheel Housings

- SAE #3

Exhaust Manifold

- rear dump down

Power Steering Pump

Wiring Harnesses

Discrete Speed Switch

Variable Speed Hand Throttle

Variable Speed Foot Pedal

Engine Mounts

- Automotive with insulators
- Open power unit

Electronic Instrument Panel, Gauges

Three Way Catalyst / Muffler Standard

Powersteering

AC Compressor

Transmissions

6R80 electronic shift

Emissions Information

California Air Resources Board (CARB)
Environmental Protection Agency (EPA)

Warranty

Contact Engine Distributors, Inc for warranty details.



Powertrain Assemblies
& Components
Provided By Ford
Component Sales

Specifications

Engine Type	V-8
Bore and Stroke	4.02" x 3.74" (102mm x 95mm)
Displacement	6.2L (379 CID)
Compression Ratio	9.8:1
Oil Capacity.....	7 qts. including filter
Net Weight	589 lbs. (267 kgs)
Dimensions	L 26.8" x W 31.1" x H 34.3" (682.2 mm x 791 mm x 873.5 mm)

Gasoline (corrected per SAE J1349)

Unleaded 87 or 89 octane		
Intermittent Power	166 [HP] @ 2800rpm	(124 [kW] @ 2800rpm)
Continuous power	150 [HP] @ 2800rpm	(111 [kW] @ 2800rpm)
Intermittent Torque	355 [ft-lbs] @ 2250rpm	(481 [N-m] @ 2250rpm)
Continuous Torque	320 [ft-lbs] @ 2250rpm	(433 [N-m] @ 2250rpm)

Natural Gas (corrected per SAE J1349)

Intermittent Power	232 [HP] @ 3600rpm	(173 [kW] @ 3600rpm)
Continuous power.....	208 [HP] @ 3600rpm	(155 [kW] @ 3600rpm)
Intermittent Torque	340 [ft-lbs] @ 3600rpm	(460 [N-m] @ 3600rpm)
Continuous Torque	305 [ft-lbs] @ 3600rpm	(413 [N-m] @ 3600rpm)

Liquefied Petroleum Gas (corrected per SAE J1349)

Intermittent Power	233 [HP] @ 3400rpm	(174 [kW] @ 3400rpm)
Continuous power.....	210 [HP] @ 3400rpm	(156 [kW] @ 3400rpm)
Intermittent Torque	365 [ft-lbs] @ 3300rpm	(494 [N-m] @ 3300rpm)
Continuous Torque	329 [ft-lbs] @ 3300rpm	(446 [N-m] @ 3300rpm)

Standard Features / Benefits

- 157 Amp Alternator - Standard
- Dual equal variable cam timing for outstanding torque
- Cam torque actuated variable cam timing optimized intake and exhaust valve opening and closing events to maximize fuel economy Dimensions
- Distributorless Ignition system and Twin spark plugs ensure a smooth stable idle and efficient combustion
- Large single intake and exhaust valves for outstanding breathing
- Individually chain-driven camshafts with a hydraulic timing chain tensioner on each timing chain
- Stiff overhead cam roller-rocker shaft valvetrain
- High-strength deep skirt block with 4 bolt mains and side bolts for strength and durability
- High compression ratio enhances engine efficiency
- Tuned composite intake manifold and ports tuned for optimal airflow for excellent torque across entire engine speed range
- Cast exhaust manifolds for heavy duty operation and durability
- Piston cooling jets for improved fuel economy and durability
- Gasoline Sequential Port Fuel Injection
- Closed loop fuel control for all fuels
- Electronic engine management system with built-in engine protection against detonation, high coolant temperature, low oil pressure, over speed shutdown and starter lockout
- Next generation governing – discrete speeds, variable speeds, drive by wire – using the highest quality components.

Installation Drawings

Front End View

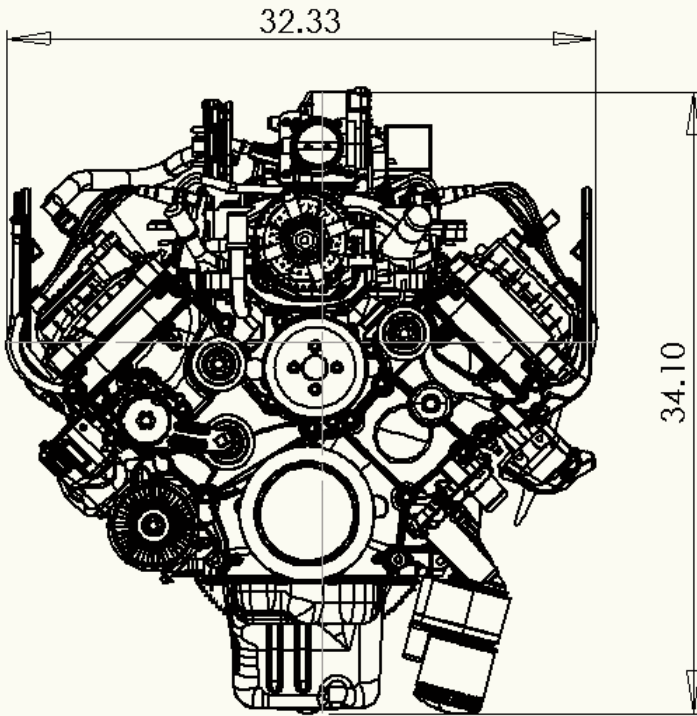

Left Side View

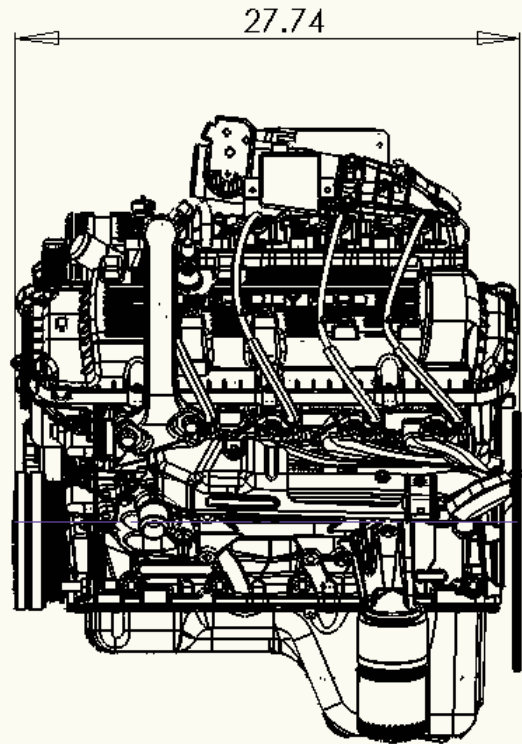

Power Curves (corrected per SAE J1349)

Gasoline

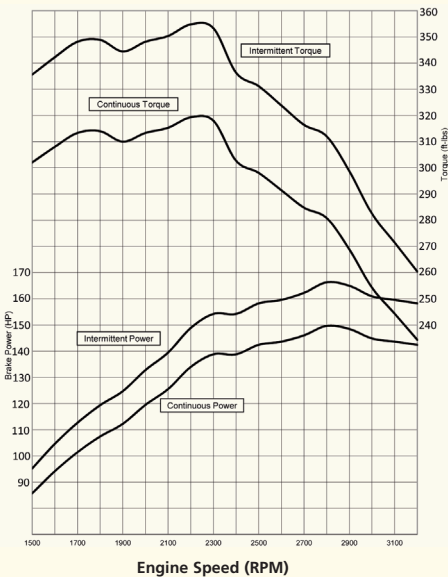

Natural Gas

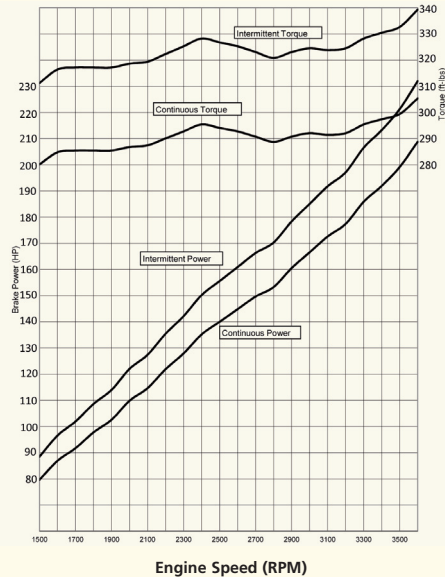

Liquefied Petroleum Gas

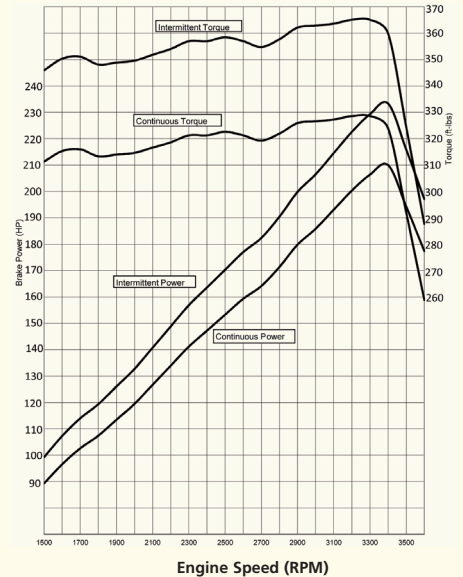

Powertrain Assemblies
& Components
Provided By Ford
Component Sales

For additional information Contact:

**ENGINE
DISTRIBUTORS
INC.**



400 University Ct • Blackwood NJ 08012
856/228-7298 • Fax:856/228-5531
www.edi-dist.com